

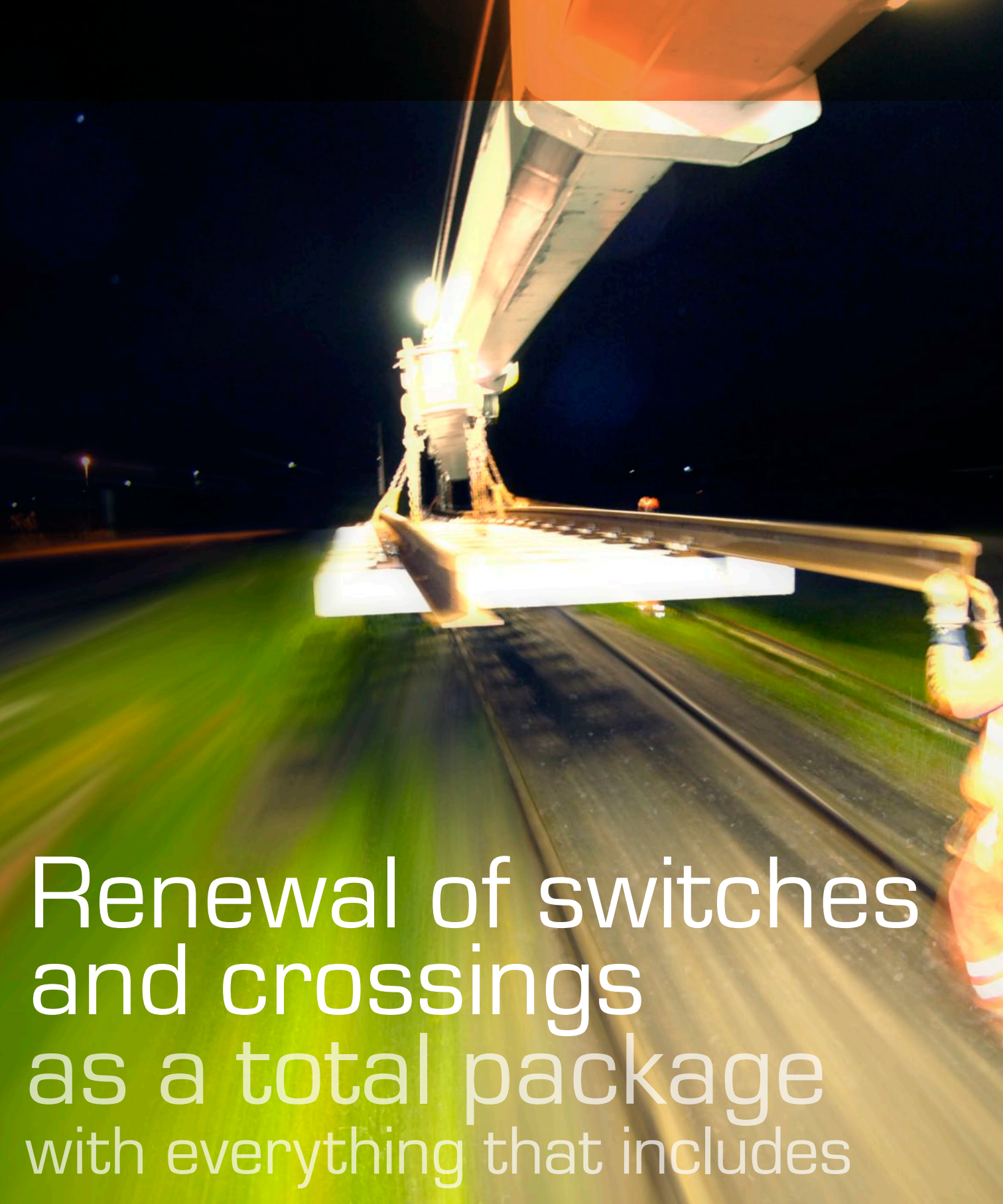

EN Total renewal of switches and crossings  
from one supplier  
Many services – one concept



**sersa** Group



Renewal of switches  
and crossings  
as a total package  
with everything that includes

## Limited time windows demand economic solutions

Switch construction projects are particularly demanding: the time window is tight – very tight, and the use of track relaying trains is not all that productive, while the co-ordination of all the individual services for the customer is difficult and complicated. Calls for a time- and cost-efficient solution became louder and louder.

**As a customer-oriented concern which understands analysis of working procedures and implement them in an economical manner, the Sersa Group took this challenge on board and developed an innovative system which now offers all the work connected with the replacement of points as a total package.**

Expertise in logistics and a broad range of products and services are the main pillars of this very time- and cost-effective concept. Not a movement is wasted, every machine is ready to work on the dot, every step interlocks with the next and builds on it. Practically tested on the SBB network and optimised for daily use, in close collaboration with the customer.

**Supreme execution, all from one source and without problematic interfaces! In Switzerland already a model of success – and in the future throughout Europe.**

### Massive time savings

through multi-disciplinary deployment of personnel, time taken for the renewal work is reduced substantially.

## Perfect planning

**... is the foundation for speedy completion of Switch and Crossing renewals.**

Our concept is based on the perfect interplay of engineering knowledge and logistical expertise. Processes scheduled to depend on one another „just-in-time“, machinery and personnel services all from one source, robust machine technology and the synergy effects within the Sersa Group all combine to reduce costs and avoid wasted production time. Neighbouring tracks remain unaffected except for brief engineering occupations and can generally even be open to traffic during the reconstruction work.

**There is plenty of brainpower behind this, as well as experience, skill and expertise.**

Our staff members are thoroughly familiar with all the procedures, jobs, deadlines and structures and are in a position to take immediate unbureaucratic action.

There is  
plenty of  
brainpower  
behind it

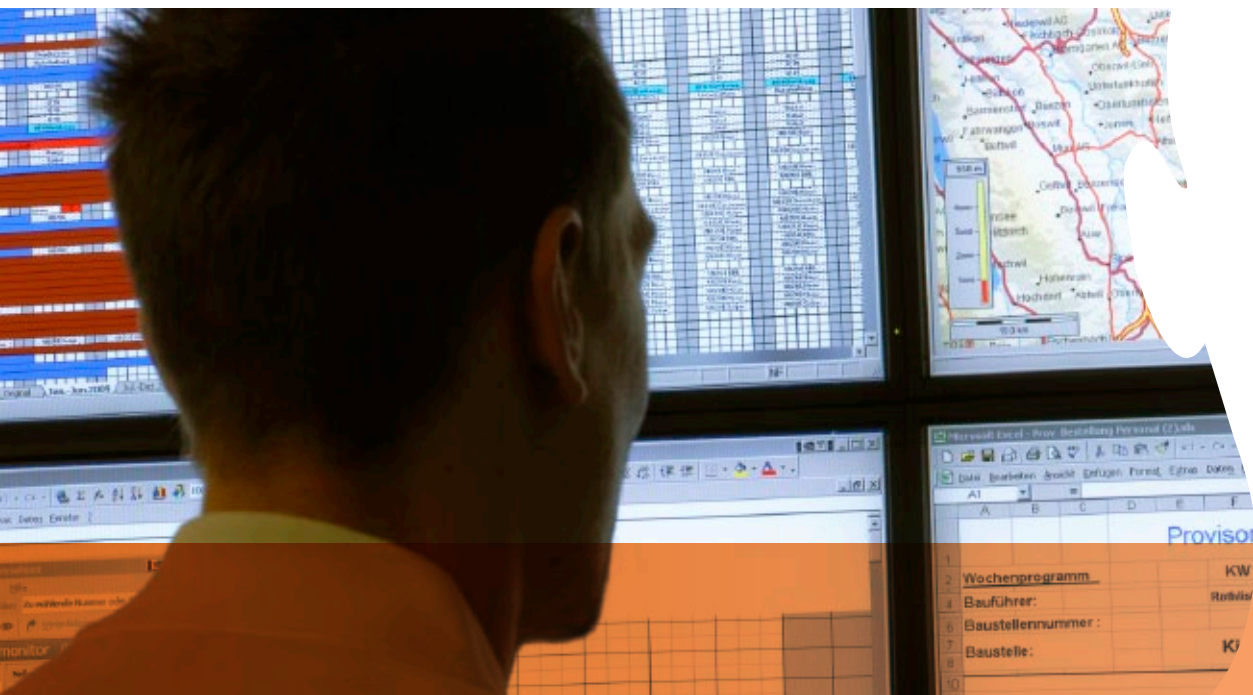

- Engineering knowledge for better efficiency

SERSA engineers are your advisers, developers and designers. Always prepared to step aside from the paths of tradition and offer more economical alternatives, which are precisely tailored to meet the needs of our customers. Some of the best examples are our own developments such as the W+ and the REINER+ ballast cleaning machine which matches it. **Two machines which are revolutionising switch and crossing renewals and can be seamlessly integrated into the overall work.**

- Far-sighted specialists

**Our staff are highly qualified, each one a master of his own sector and specially trained in the working procedures surrounding total renewals.** Not individualists, but a dedicated team which functions well, its members complementing each other, always keeping the overall picture in view, supporting each other as necessary and working hand in hand.



You profit  
from all of this !



## Modular arrangement

Total renewal of switches and crossings functions according to the building block principle, and is composed of many parts fitting in to complete the puzzle. **Due to this modular arrangement, it is possible to consider and make plans for each construction site individually.** Procedures are not rigid, but are flexible to allow for deviations. Despite this, all working stages are precisely harmonised with one another.

**But: in order to take the fullest advantage of the efficiency of the process overall, we recommend you to make use of our services.** We have repeatedly examined the procedures for economy in operation, making adjustments here, a little fine tuning there. Consequently, each member of the dedicated staff, each element of the project, each machine used fits into the procedure 100%.

# Many components to make the Whole

## Total replacement of switches and crossings

Not a movement is wasted, every machine starts to work on the dot, every step interlocks with the next and builds on it.



# Thoroughly

## The W+

our high-performance new development for the total renewal of switches and crossings

**Modern machine technology makes a major contribution to speeding up and to the quality of switch and crossing renewal.**

One core of the total replacement of switches and crossings is the new W+, for excavating the old ballast bed, for relaying cleaned ballast and fresh ballast and compaction of the new ballast bed.

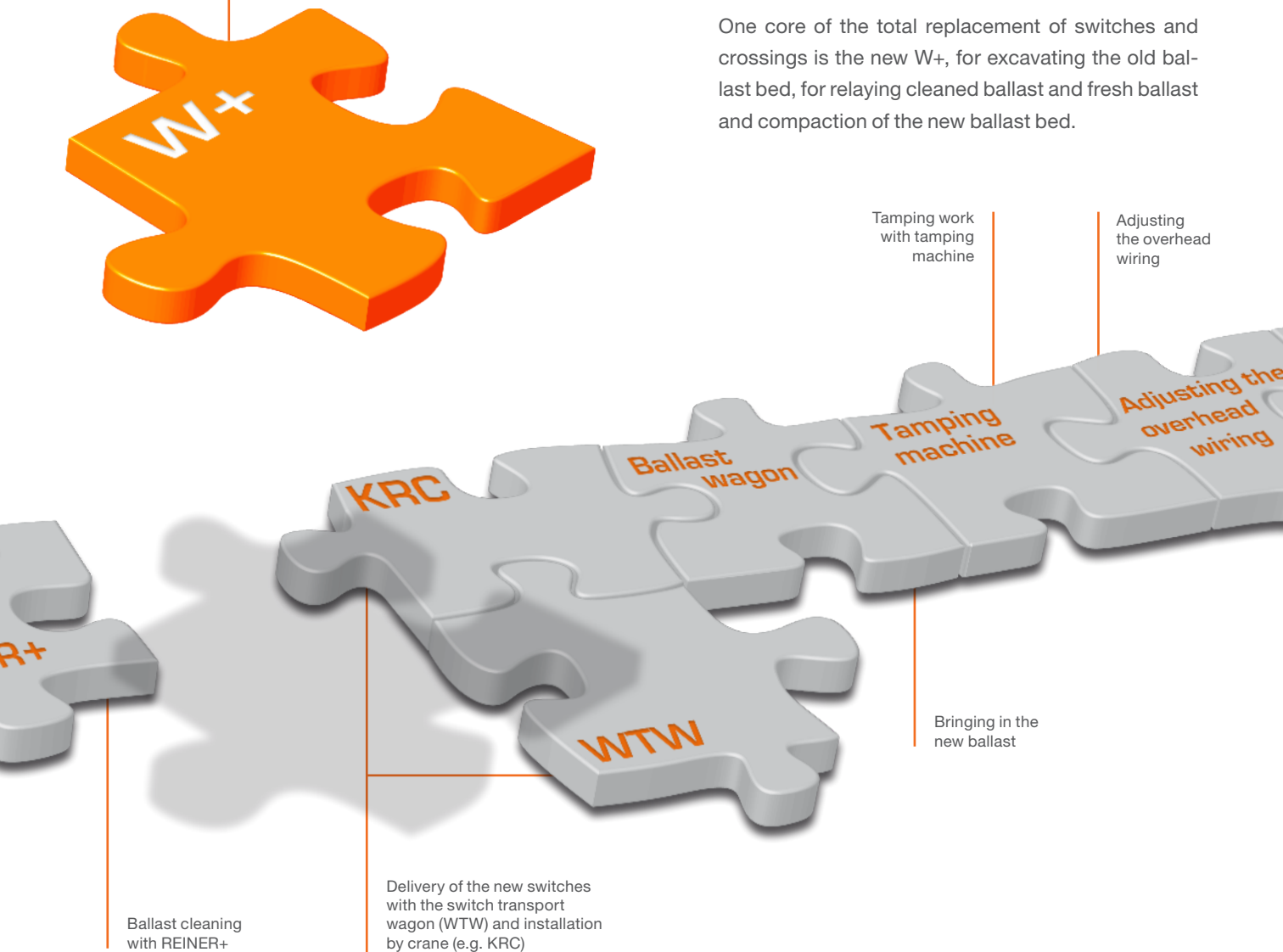

modern machinery

High

**Everyone who sees the W+ working is impressed.**

The two large impellers and the formation compactor are instantly striking. An impressive machine, and not just optically. Because the Sersa Group's own developments are revolutionising switch and crossing renewal.

With an excavation capacity of up to 250 m<sup>3</sup>/h and an excavation width of over 8 m, the W+ achieves better performances than anything previously.

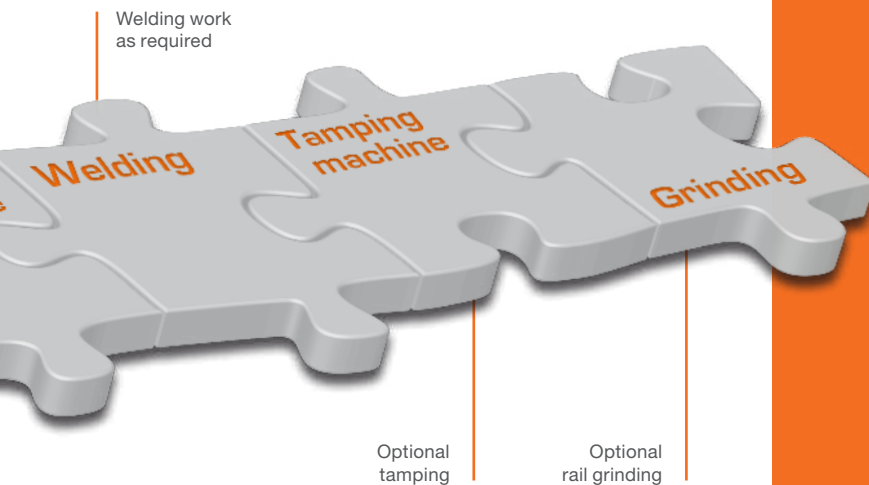
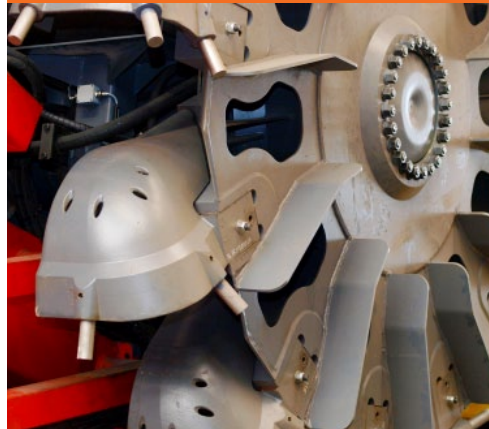

**Savings in time are substantial, completion of engineering work is much faster and engineering occupations can be given up much more quickly.**

The W+ works on crawler tracks, but is fitted with additional railway running gear for transport to the site of work. Trips between the sites of work are carried out on a special transport wagon on the rails.



performances





## W+ and REINER+: strength in combination

The excavation capacity of the W+ requires a well-planned and high-powered spent material transport over the AVES conveyor system. The excavated material is transported to the rear by conveyor belts to the REINER+ ballast cleaner. From there, cleaned ballast is returned to the W+ and at the same time the new ballast bed is laid. In the same working step, the excavated foundation and the ballast foundation is compacted. The machine moves in reverse so that the new rails can be laid directly compaction is completed, and thus there is an uninterrupted flow of work possible.

### The impeller

Specially developed for excavation ballast beds: compact, very efficient and quiet in operation. The maximum excavation depth is 1300 mm from top of sleeper.

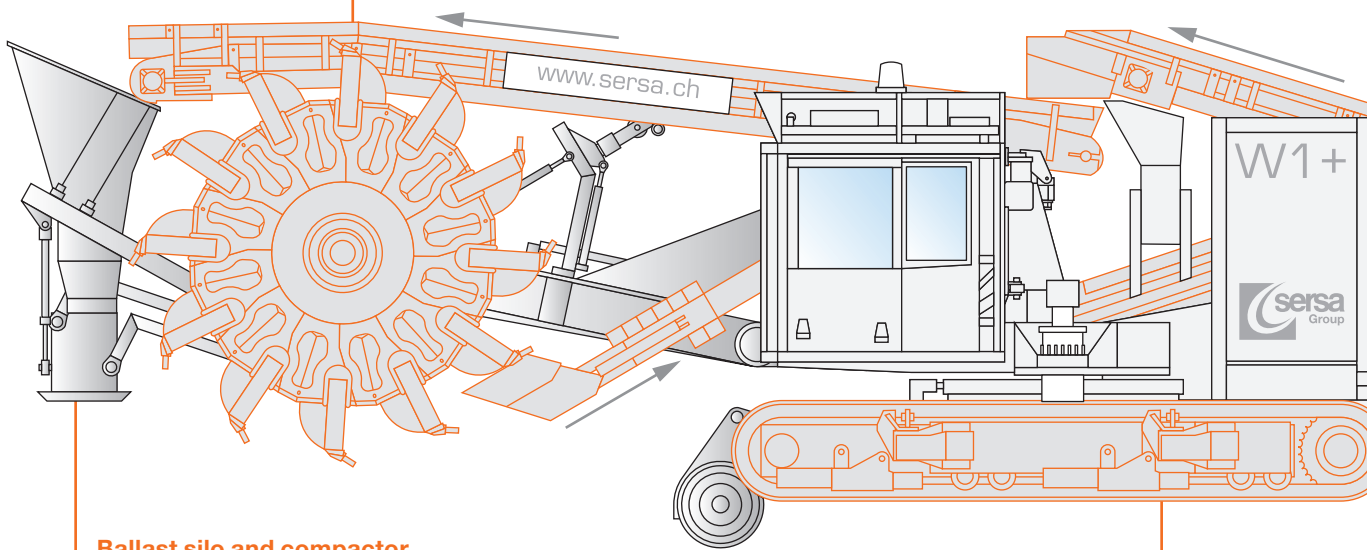

### Ballast silo and compactor

The cleaned ballast is fed into the adjustable-height ballast silo, which then discharges it into the trackbed via the foundation compactor. Excavation and compaction are carried out in a single continuous working operation, avoiding any standstills.

### W+ and REINER+

A team used to working together: when working in combination, W+ and REINER+ reach top form and achieve maximum performance and efficiency.

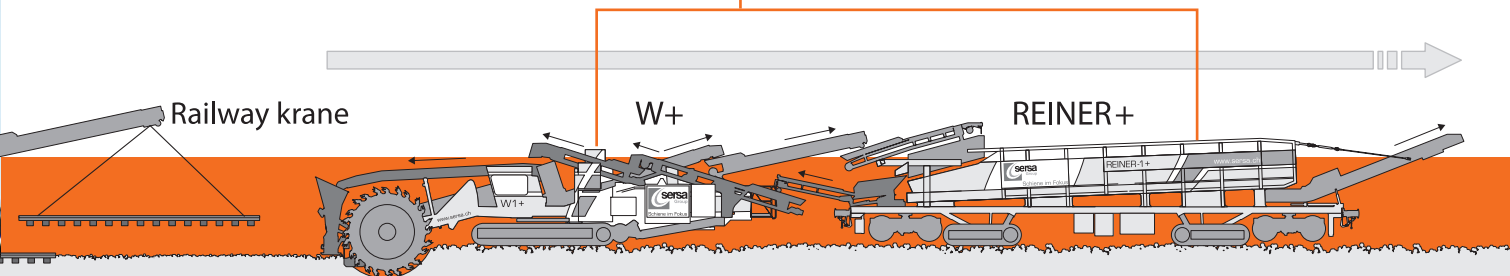

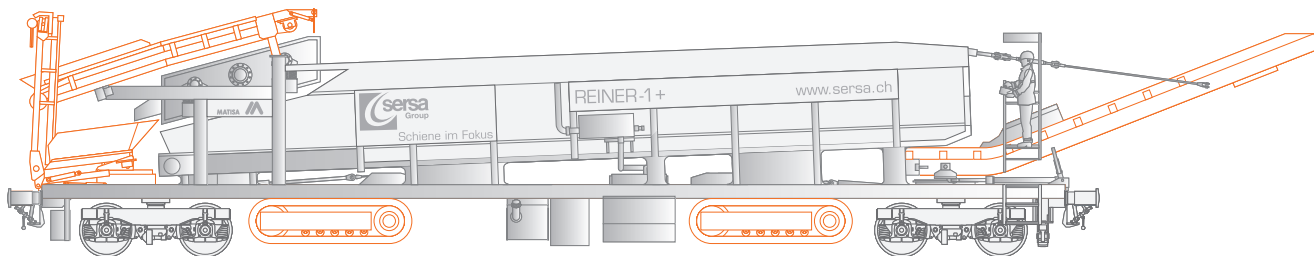

REINER+ can in addition be used as a shuttle, although it is more efficient to use a standard AVES+ for carrying away the spent material, as this avoids any delays in the course of work.

### Measuring and control concept

The latest measuring technology employed on the W+ permits the excavation and track foundation to be carried out precisely and with different gradient angles. Excavation depths and widths are measured with goniometers and fed into the calculation and control unit. This then prescribes the height and transverse positioning for excavations and track foundations.

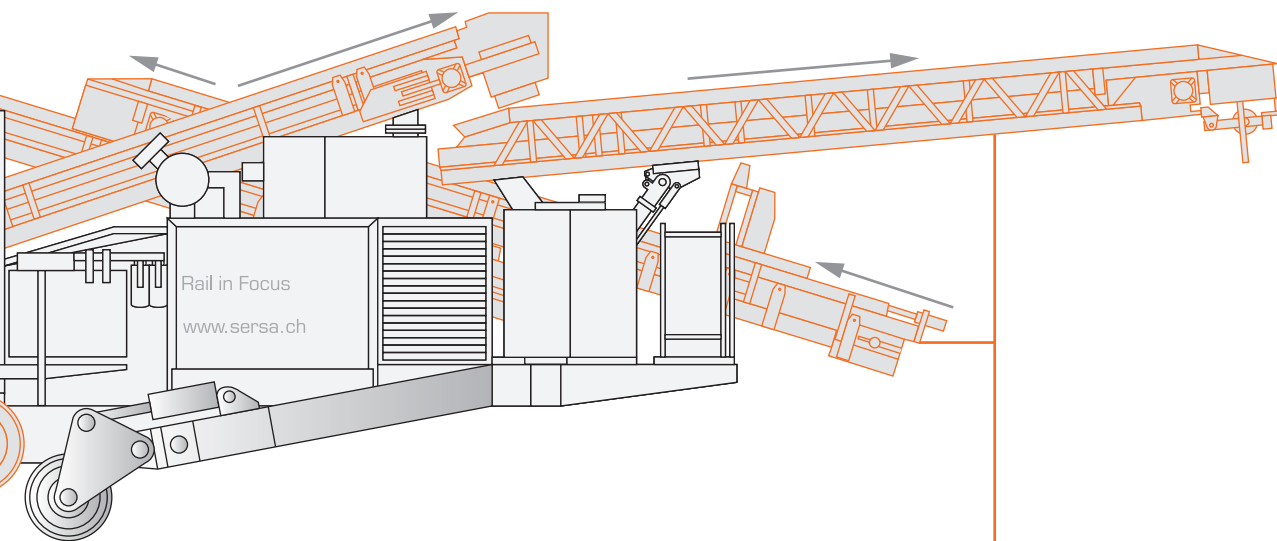

### + crawler running gear

In addition to their rail bogies, W+ and REINER+ are also fitted with two crawler tracks so that they can operate over sections without rails.

### Transport of the ballast

The material excavated is transported to the rear on a conveyor belt to the AVES conveyor system. If the ballast is to be cleaned, the AVES special REINER+ is used, and the cleaned ballast is then returned immediately to the W+ on another conveyor belt.

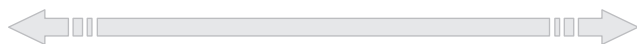

AVES +

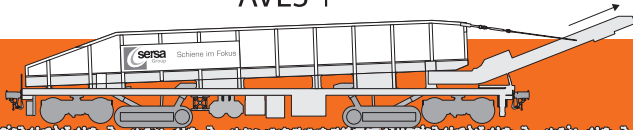

AVES



## These are the services you can expect from us:

- Site supervision
- Fitting in the new switches and crossings with Switchcontrol
- Transporting the switches and crossings with the switch transport wagon WTW (01)
- Cranage: unloading the new switches, loading up the old switches, removal of the old switches and crossings (02)
- Excavation of the ballast bed and transporting the spoil away (03/04)
- Ballast cleaning
- Return, discharge and compaction of the cleaned ballast
- Installing the new switches and crossings (05/06)
- Unloading ballast
- Levelling, lining and tamping – the track is ready for traffic again
- Adjusting the overhead wiring (FL)
- Welding and destressing (07)
- Grinding work

01



02



03

**Well planned:**  
flow-chart for the complete  
replacement of switches and  
crossings



Briefing

Preparing the  
site of work

Equipping the  
machines





### Blocking the track

cutting the rails, bringing in the machines, removal of the switches and crossings



### Excavation and compaction

W+



### Ballast cleaning and transport

REINER+  
AVES+  
AVES

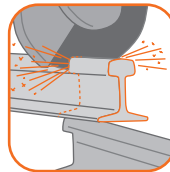

### Installation of the switches and crossings

### Transporting the old switches and crossings away with switch transport wagon

WTW

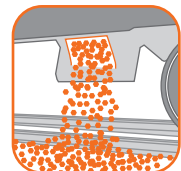

### Unloading ballast





04



06



05



07

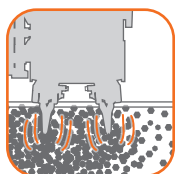

Tamping

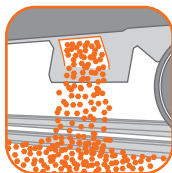

Topping-up ballast

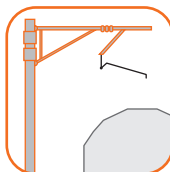

Adjusting overhead wiring



Lifting the engineering block

Return of the machines

Handover notification of fitness for traffic

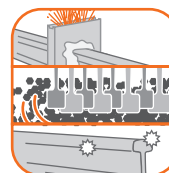

Optional

Welding  
Tamping  
Grinding



## The advantages of the complete renewal of switches and crossings

- **massive savings in time**
- **shorter line blockages**
- **cost minimisation**
- flowing and continuous **working operation of all processes**
- tracks are available for rail traffic immediately **after the switches and crossings are installed**
- improved **quality**
- utilisation of **synergy effects**
- **streamlining** the whole supply chain

You profit from the know-how  
of the Sersa Group



# sersa



**Contact International/Switzerland**

+41 43 322 23 23

**Contact Germany**

+49 30 56 54 660

**Contact Netherlands**

+31 75 612 40 81

**Contact UK**

+44 1904 47 99 68

[info@sersa.ch](mailto:info@sersa.ch)

[www.sersa.ch](http://www.sersa.ch)

[www.sersa.ch](http://www.sersa.ch)